

ASTR-4240 — Gravitation & Cosmology
PHYS-4240 — General Relativity

Class 1
Newtonian Gravity

Exercise (30 pts)

Suppose that we model the mass distribution of our Milky Way galaxy as an infinite sheet of thickness H and uniform mass density ρ .

1. (10 pts) — Let z be vertical distance measured from $z = 0$ at the midplane of the disk. Find the gravitational field \mathbf{g} (magnitude and direction) as a function of z .
2. (10 pts) — A star is initially at rest at some position z_0 . Find its trajectory $z(t)$ in terms of the quantities given.
3. (10 pts) — What is the period of the motion in years if the disk contains $50 M_\odot$ in a 1 pc^2 column? Assume that $H = 50 \text{ pc}$.

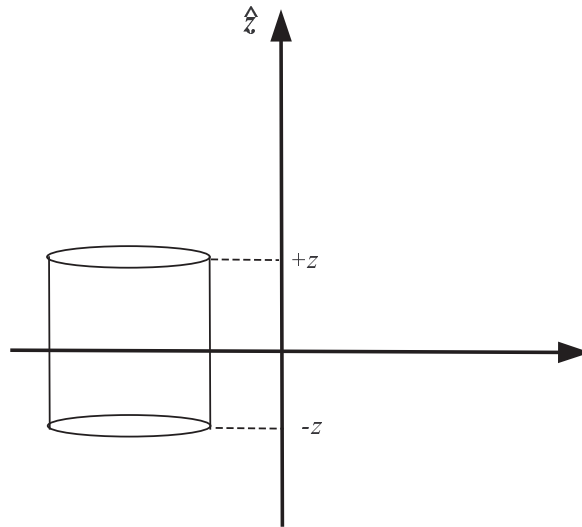

Solution

1. By symmetry, we must have $\mathbf{g} = -g(z)\hat{z}$, where g denotes the magnitude of g (a positive number). Now apply Gauss's Law to a cylindrical surface with endcaps (area A) at $\pm z$:

$$\oint_S \mathbf{g} \cdot \hat{\mathbf{n}} dA = -4\pi G \int_V \rho dV. \quad (1)$$

The sides of the cylinder give no contribution and each endcap gives $-g(z)A$. Thus

$$-2g(z)A = -4\pi G \times 2z\rho A \quad (2)$$

and

$$\boxed{\mathbf{g}(z) = -4\pi G\rho z \hat{z}.} \quad (3)$$

2. If

$$\omega \equiv \sqrt{4\pi G\rho}, \quad (4)$$

then the equation of motion for $z(t)$ is

$$\frac{d^2 z}{dt^2} = -\omega^2 z. \quad (5)$$

The solution subject to the boundary conditions $z(0) = z_0$ and $\dot{z}(0) = 0$ is

$$\boxed{z(t) = z_0 \cos \omega t.} \quad (6)$$

The data imply a mass density of $\rho = 6.8 \times 10^{-23} \text{g cm}^{-3}$.

3. The period is

$$T = \frac{2\pi}{\omega} = 8.3 \times 10^{14} \text{s} = \boxed{26 \text{Myr}.} \quad (7)$$