

Lab 3. Transistor and Logic Gates

Laboratory Instruction

Today you will learn how to use a transistor to amplify a small AC signal as well as using it as a switch to construct digital logic circuits.

Introduction

- The TA will show you the emitter, base and collector for the transistor.
- The TA will show you how to mount Integrated Circuits (IC) on a breadboard.

Waveform Identification

- 3.1 Turn on the oscilloscope and connect the output of the function generator to channel 1. Determine what is the waveform you are looking at. Measure the amplitude, frequency, and DC offset. Note this information on the answer sheet. Show all your calculations on the answer sheet for frequency, amplitude, and DC offset. Draw a picture of the signal that you see on the scope.

Signal Amplification using Bipolar Junction Transistor (BJT)

- 3.2 Transistors are commonly used for amplifying weak AC signals. We have studied in lecture that transistors may operate in three different modes, cutoff, linear, and saturation. For amplification purposes a transistor is biased for linear operation. For switching purposes a transistor is biased either in cutoff or saturation.

Signal Amplification using Bipolar Junction Transistor (BJT)

3.2 Continued.

Make the circuit below using a BJT, 2N2222 transistor. Apply a 1 kHz sine wave at the input with a peak-to-peak amplitude of 0.250 volts, with zero volts DC offset. Adjust the potentiometer so that it is in the center of its travel. Using the oscilloscope, find the shape of the waveforms at the input, (applied signal), and across the output load resistor, (amplified wave). Set both channels to DC coupling. Draw the waveforms as observed on the oscilloscope. What is the amplification ratio (gain) of the transistor? Is the output signal in or out of phase?

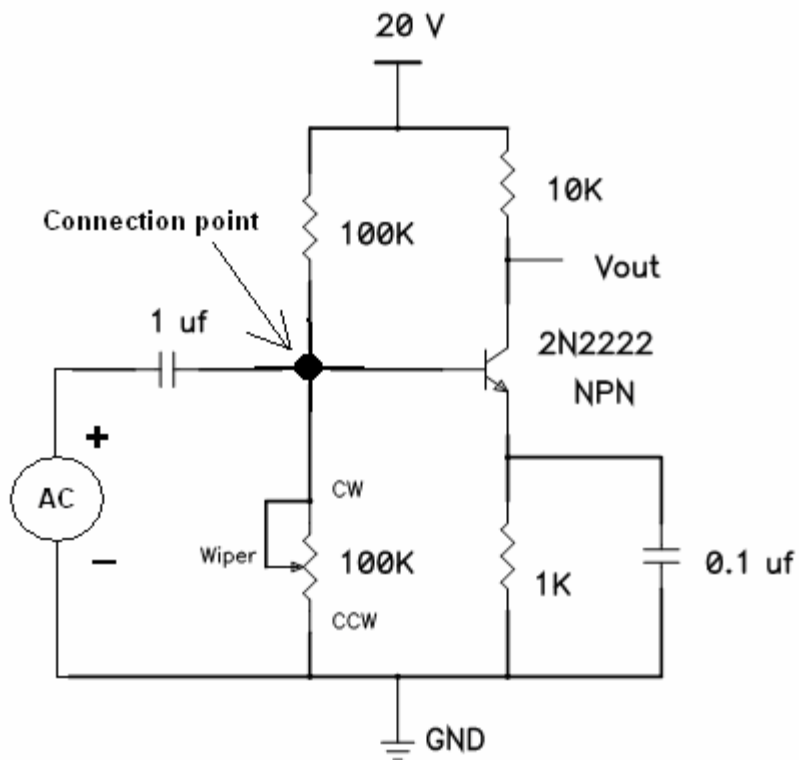
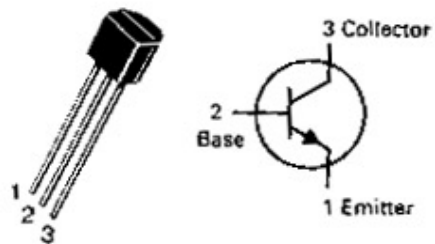

2N2222 BJT WITH VARIABLE BIAS POTENTIOMETER

The 1uf capacitor, 100K resistor and 100K potentiometer are all connected to the base of the transistor. The clockwise (CW) terminal of the potentiometer is connected by an external wire to the wiper (W) terminal of the potentiometer. The 100K potentiometer is a 25 turn device.

While monitoring the output, slowly adjust the potentiometer either clockwise (CW) or counter clockwise (CCW) and observe the output. Draw the waveform when you are in cutoff and saturation.

Digital Circuits (Logic Gates)

3.3 Assemble the circuit below. Construct the logic or truth table. The logic table represents input (A,B) versus output (Y) states. Any current flowing through the input or output represents a state of "1". Hence when the switch at the input is closed (ON), the input state is "1". Similarly, when the output diode emits light (current flows), the output state is "1". The state "0" is the OFF state for the switch and the diode. When using a meter to determine the state of the output of a TTL digital circuit, any voltage between 3.6-5.0 volts is considered a logic "1". If the voltage is between 0-1.8 volts it is considered to be a logic "0". What type of logic gate do you have? To identify the logic gate, use truth tables.

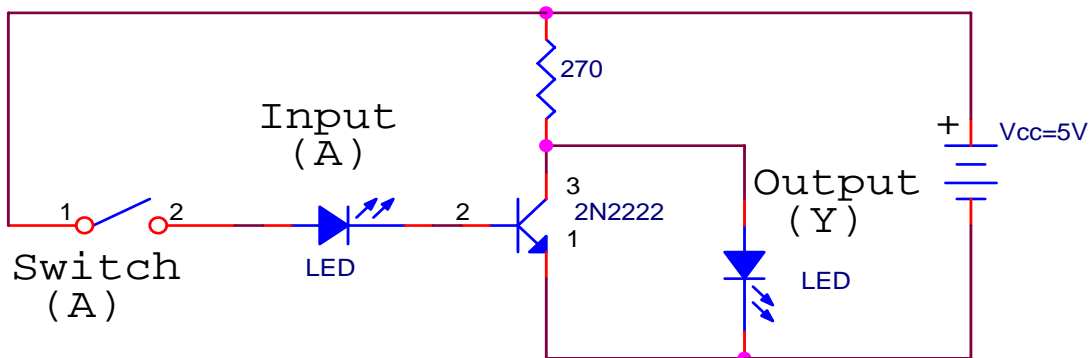

3.4 Assemble the circuit below. Construct the logic or truth table. What type of logic gate do you have? To identify the logic gate, use the truth tables.

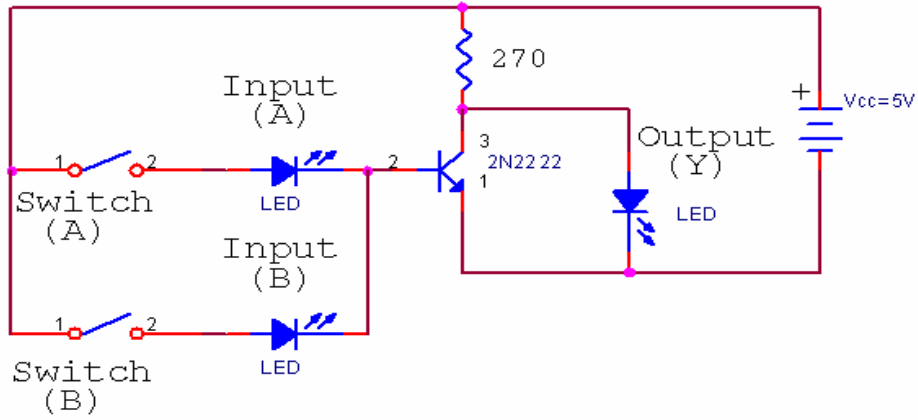

3.5 Identify the logic gate type for the IC (MC14081B) given to you in the laboratory. Connect the circuit below to construct the truth table.

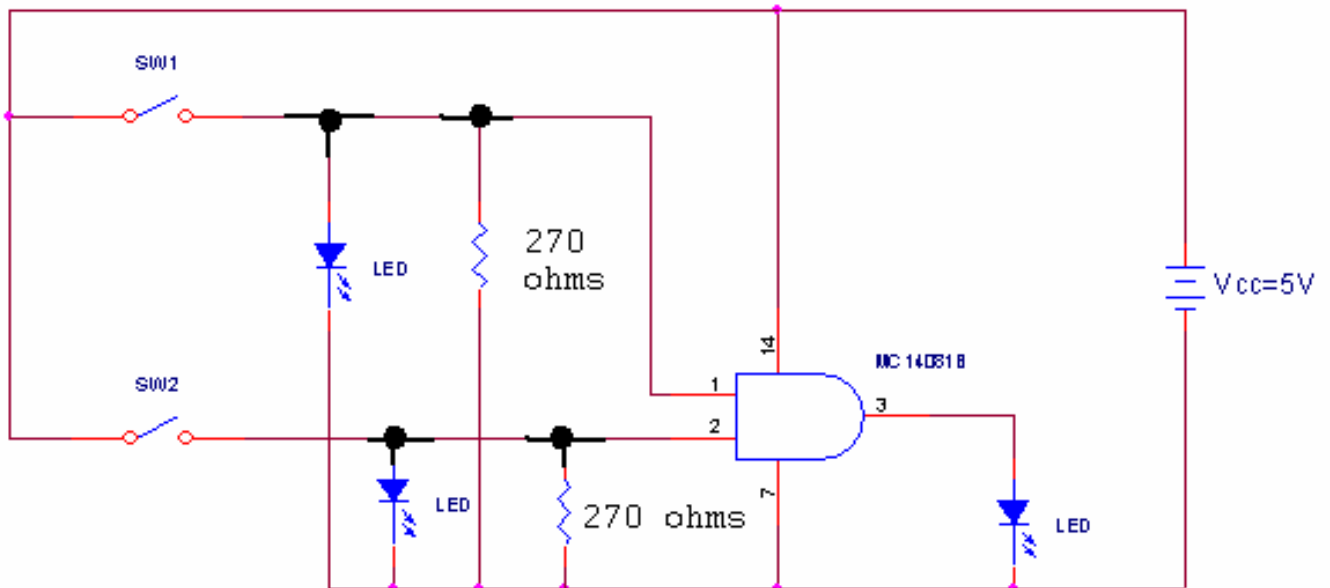

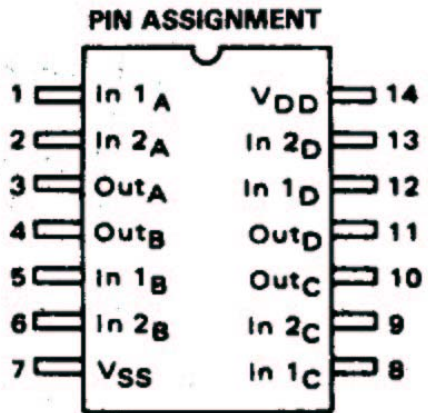







MC 14081B Pin out diagram

Digital Logic Gates

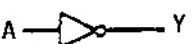
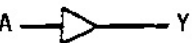
A,B: Inputs

Y: Output

Name	Symbol	Algebraic function	Truth table															
AND		$Y=AB$	<table border="1"> <thead> <tr> <th>A</th> <th>B</th> <th>Y</th> </tr> </thead> <tbody> <tr><td>0</td><td>0</td><td>0</td></tr> <tr><td>0</td><td>1</td><td>0</td></tr> <tr><td>1</td><td>0</td><td>0</td></tr> <tr><td>1</td><td>1</td><td>1</td></tr> </tbody> </table>	A	B	Y	0	0	0	0	1	0	1	0	0	1	1	1
A	B	Y																
0	0	0																
0	1	0																
1	0	0																
1	1	1																
OR		$Y=A+B$	<table border="1"> <thead> <tr> <th>A</th> <th>B</th> <th>Y</th> </tr> </thead> <tbody> <tr><td>0</td><td>0</td><td>0</td></tr> <tr><td>0</td><td>1</td><td>1</td></tr> <tr><td>1</td><td>0</td><td>1</td></tr> <tr><td>1</td><td>1</td><td>1</td></tr> </tbody> </table>	A	B	Y	0	0	0	0	1	1	1	0	1	1	1	1
A	B	Y																
0	0	0																
0	1	1																
1	0	1																
1	1	1																
(NOT) Inverter		$Y=\bar{A}$	<table border="1"> <thead> <tr> <th>A</th> <th>Y</th> </tr> </thead> <tbody> <tr><td>0</td><td>1</td></tr> <tr><td>1</td><td>0</td></tr> </tbody> </table>	A	Y	0	1	1	0									
A	Y																	
0	1																	
1	0																	
Buffer		$Y=A$	<table border="1"> <thead> <tr> <th>A</th> <th>Y</th> </tr> </thead> <tbody> <tr><td>0</td><td>0</td></tr> <tr><td>1</td><td>1</td></tr> </tbody> </table>	A	Y	0	0	1	1									
A	Y																	
0	0																	
1	1																	
NAND		$Y=\overline{AB}$	<table border="1"> <thead> <tr> <th>A</th> <th>B</th> <th>Y</th> </tr> </thead> <tbody> <tr><td>0</td><td>0</td><td>1</td></tr> <tr><td>0</td><td>1</td><td>1</td></tr> <tr><td>1</td><td>0</td><td>1</td></tr> <tr><td>1</td><td>1</td><td>0</td></tr> </tbody> </table>	A	B	Y	0	0	1	0	1	1	1	0	1	1	1	0
A	B	Y																
0	0	1																
0	1	1																
1	0	1																
1	1	0																
NOR		$Y=\overline{A+B}$	<table border="1"> <thead> <tr> <th>A</th> <th>B</th> <th>Y</th> </tr> </thead> <tbody> <tr><td>0</td><td>0</td><td>1</td></tr> <tr><td>0</td><td>1</td><td>0</td></tr> <tr><td>1</td><td>0</td><td>0</td></tr> <tr><td>1</td><td>1</td><td>0</td></tr> </tbody> </table>	A	B	Y	0	0	1	0	1	0	1	0	0	1	1	0
A	B	Y																
0	0	1																
0	1	0																
1	0	0																
1	1	0																
Exclusive OR (XOR)		$Y=\bar{A}B + A\bar{B}$ $y=A\oplus B$	<table border="1"> <thead> <tr> <th>A</th> <th>B</th> <th>Y</th> </tr> </thead> <tbody> <tr><td>0</td><td>0</td><td>0</td></tr> <tr><td>0</td><td>1</td><td>1</td></tr> <tr><td>1</td><td>0</td><td>1</td></tr> <tr><td>1</td><td>1</td><td>0</td></tr> </tbody> </table>	A	B	Y	0	0	0	0	1	1	1	0	1	1	1	0
A	B	Y																
0	0	0																
0	1	1																
1	0	1																
1	1	0																
Exclusive NOR or equivalence		$Y=AB + \bar{A}\bar{B}$ $Y=A\odot B$	<table border="1"> <thead> <tr> <th>A</th> <th>B</th> <th>Y</th> </tr> </thead> <tbody> <tr><td>0</td><td>0</td><td>1</td></tr> <tr><td>0</td><td>1</td><td>0</td></tr> <tr><td>1</td><td>0</td><td>0</td></tr> <tr><td>1</td><td>1</td><td>1</td></tr> </tbody> </table>	A	B	Y	0	0	1	0	1	0	1	0	0	1	1	1
A	B	Y																
0	0	1																
0	1	0																
1	0	0																
1	1	1																

Answer Sheet

Lab 3. Transistor and Logic Gates

Name: _____ Section Number: _____
TA init: _____ Date: _____

3.1 Draw the waveform. Determine amplitude, frequency, and DC offset. Show calculations.

3.2 Draw output waveform showing the linear, cutoff, and saturation conditions. Compute the voltage gain. In linear operation is the output signal in or out of phase?

3.3 Truth Table

Truth or Logic Table

Input (A)	Output (Y)
1	
0	

What type of gate is this?

Answer Sheet

Lab 3. Transistor and Logic Gates

Name: _____ Section Number: _____
 TA init: _____ Date: _____

3.4 Truth table:

Truth table for two input gate

Input (A)	Input (B)	Output (Y)
0	0	
0	1	
1	0	
1	1	

What type of gate is this?

3.5 Truth Table:

Truth table for the MC14081B

Input (A)	Input (B)	Output (Y)
0	0	
0	1	
1	0	
1	1	

What type of gate is this?